

ergofocus de exterior

© atelier dominique imbert, 2015.



Instruções específicas

Specific instructions Instruzione individuale Modellspezifische Hinweise Individuelle instructie Instrucción individual Дополнительные инструкции Supplerende anvisninger Täiendavad juhised Mallikohtaiset ohjeet ατομική κάρτα ενημέρωσης Τονάββι utasítások specifiskā instrukcija Individuali instrukcija Fisa individuala Indywidualna instrukcja obsługi Noticia individual Dodatočné inštrukcie Dodatna navodila Särskilda instruktioner Individuální návod Struzzjonijiet addizzjonali Индивидуална информация карта

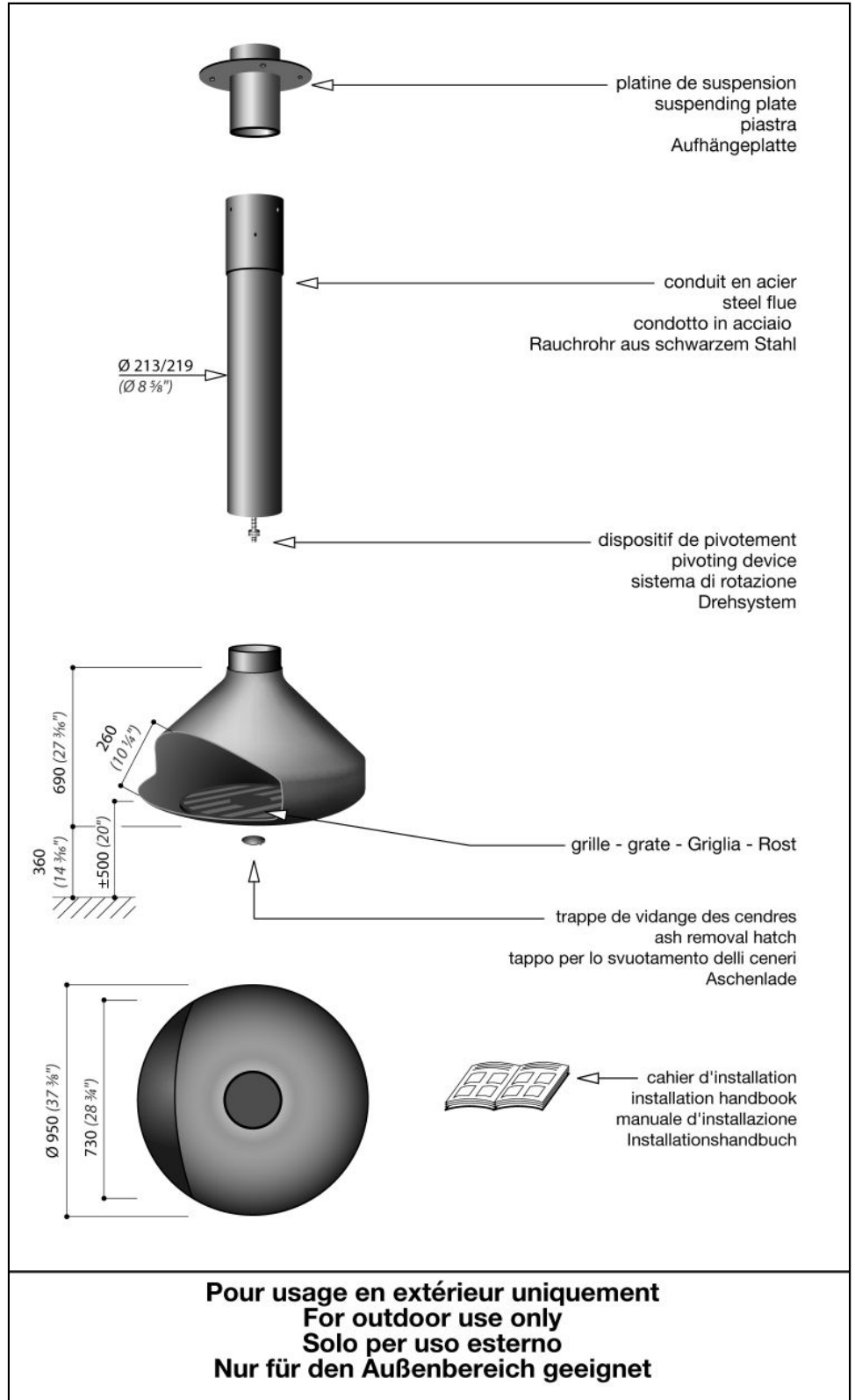

30/04/2019

focus

Atelier Dominique Imbert s.a.s
34380 Viols le fort - France
téléphone : +33 (0)4 67 55 01 93
télécopie : +33 (0)4 67 55 77 77
info@focus-creation.com
http://www.focus-creation.com

ergofocus de exterior

© atelier dominique imbert, 2015.

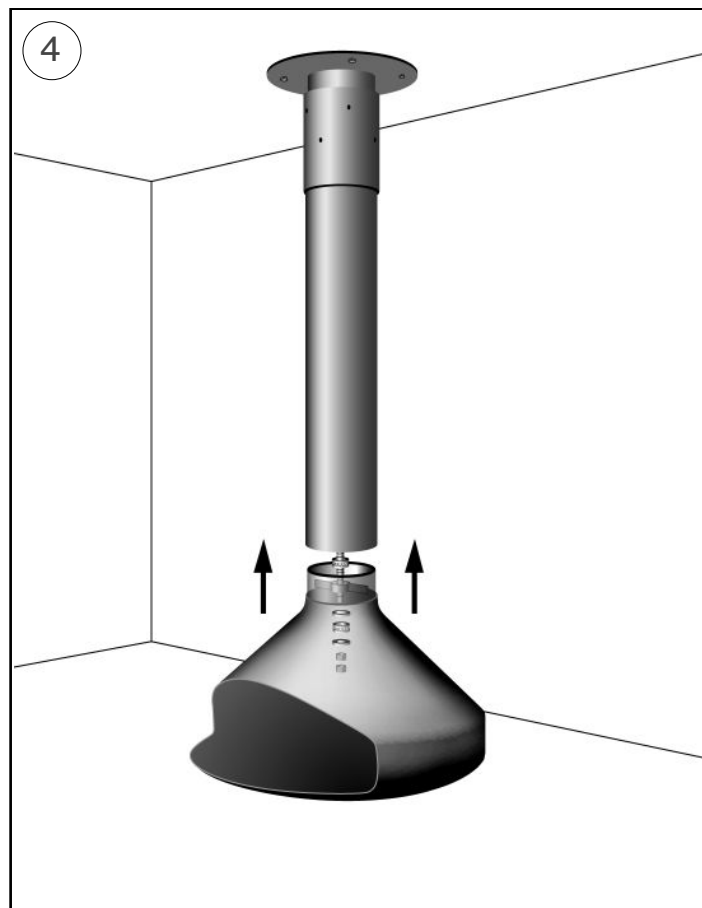
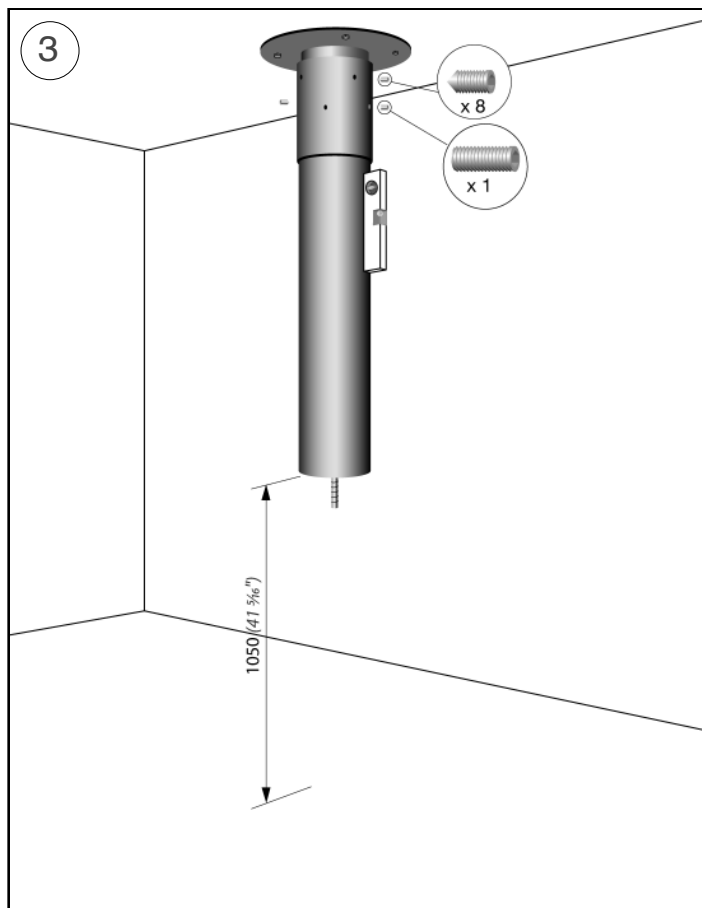
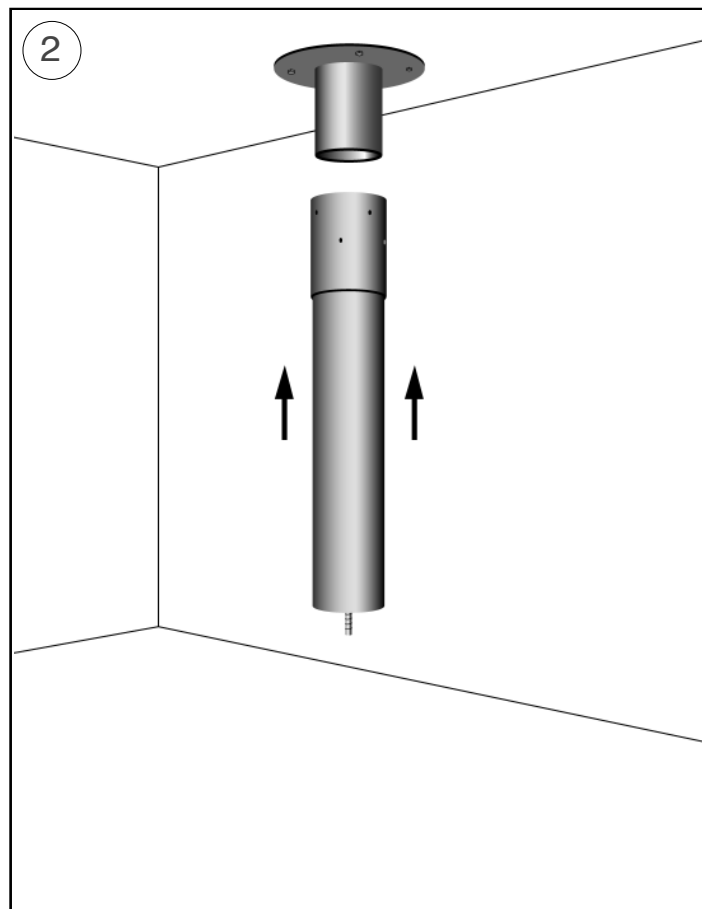
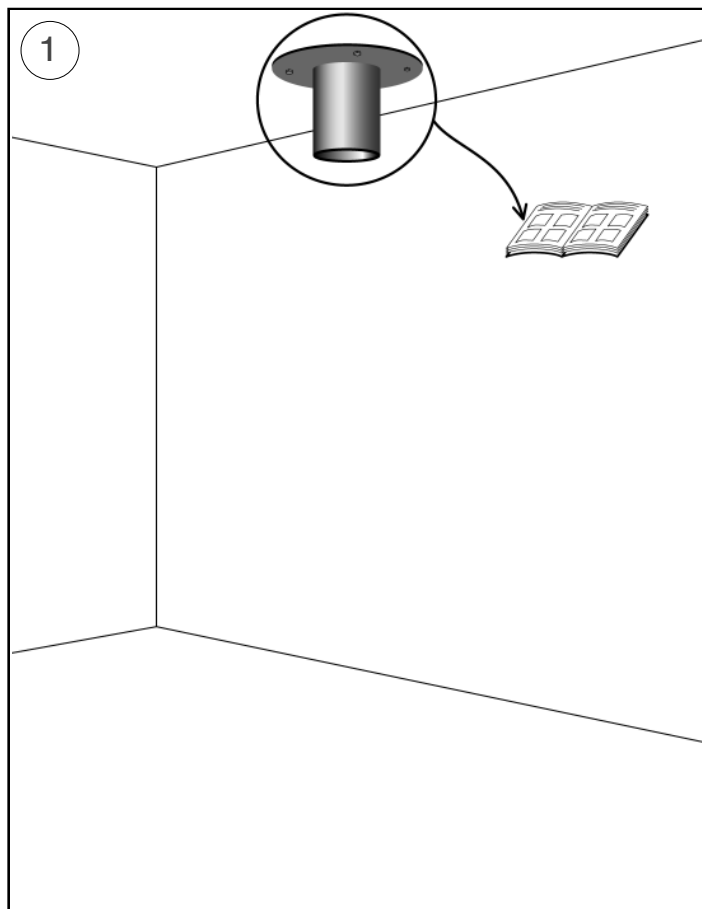

ergofocus de exterior

© atelier dominique imbert, 2015.

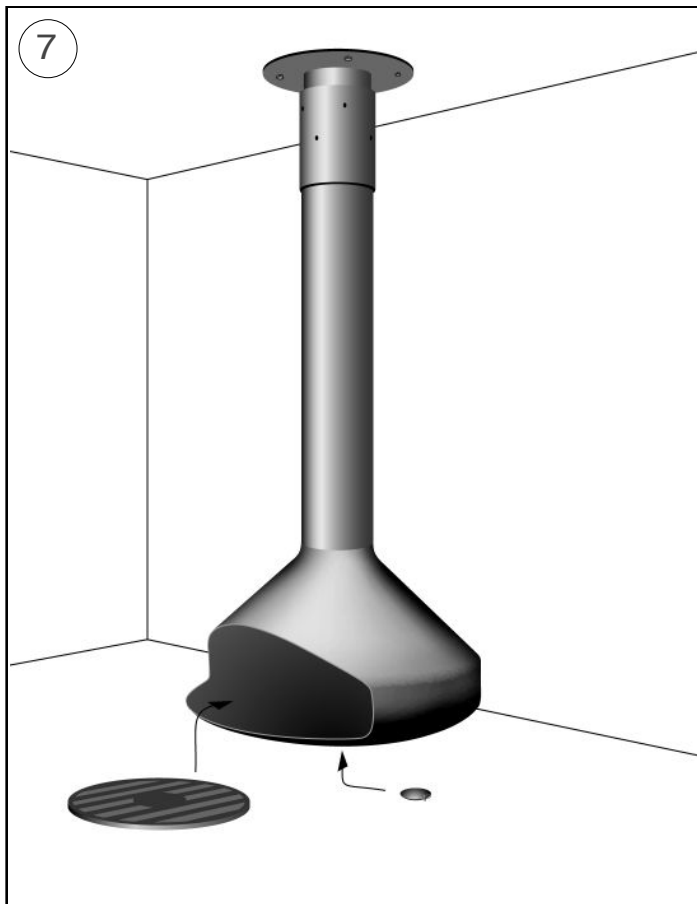
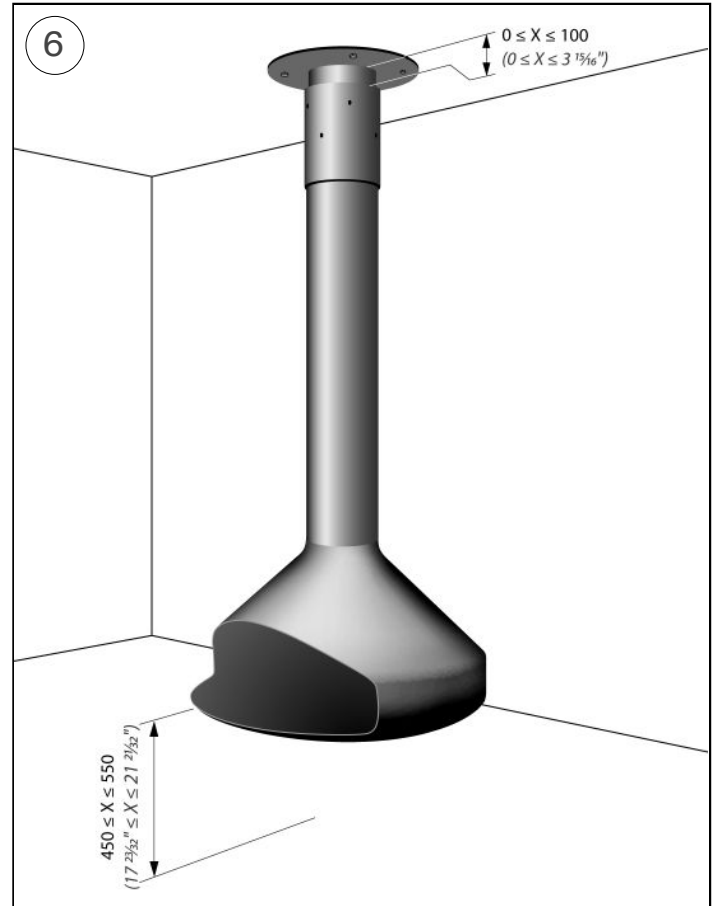
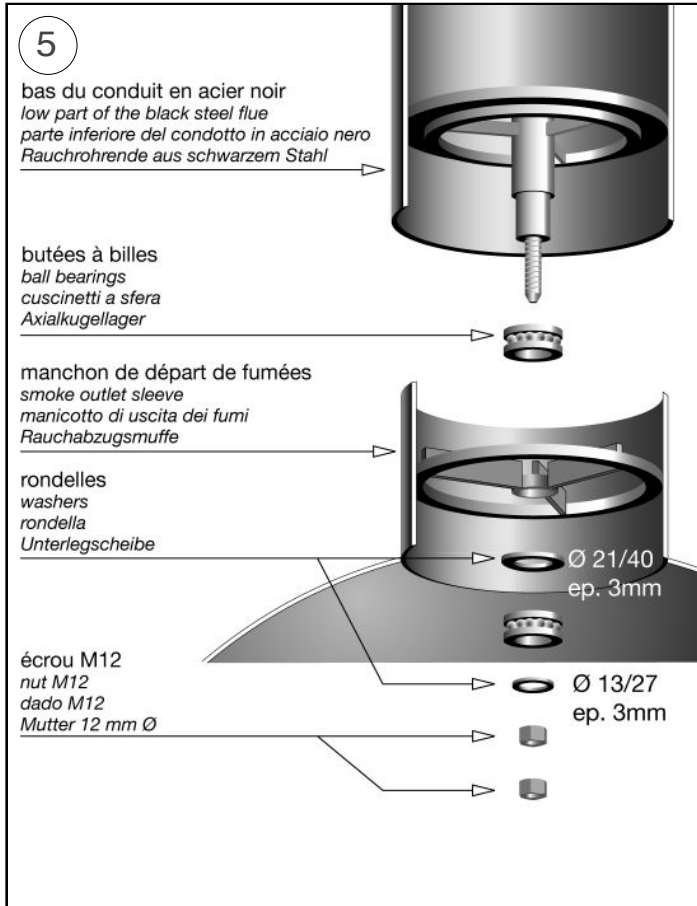

ergofocus de exterior

© atelier dominique imbert, 2015.

Distâncias de segurança para materiais inflamáveis.

Safety clearance distances from combustible materials.

Mindestabstand hinsichtlich der brennbaren Materialien.

Distanze di sicurezza da ogni materiale combustibile.

distancias de seguridad con relación a los materiales combustibles

Veilige afstand tot brandbaar materiaal.

Sikkerheds afstand til brændbart materiale.

OHUTU KAUGUS PÕLEVmaterjalidEST.

Suojaetäisyydet palava-aineiseen materiaalin.

αποστάσεις ασφαλείας από εύφλεκτα υλικά.

Biztonsági távolság gyúlékony anyagoktól.

Droša distance no viegli uzliesmojošiem materiāliem.

Leistinas saugus atstumas nuo degių medžiagų.

Distanzi li jridu jithallew minn kull materjal li jista jaqbad.

Minimalne odległości bezpieczeństwa od materiałów palnych.

Distâncias de segurança em relação aos materiais combustíveis.







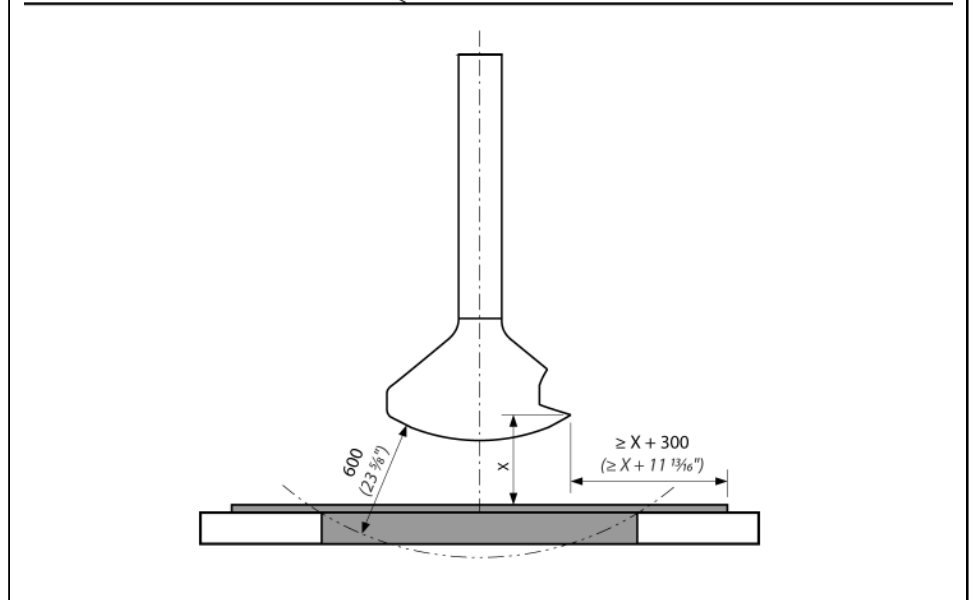
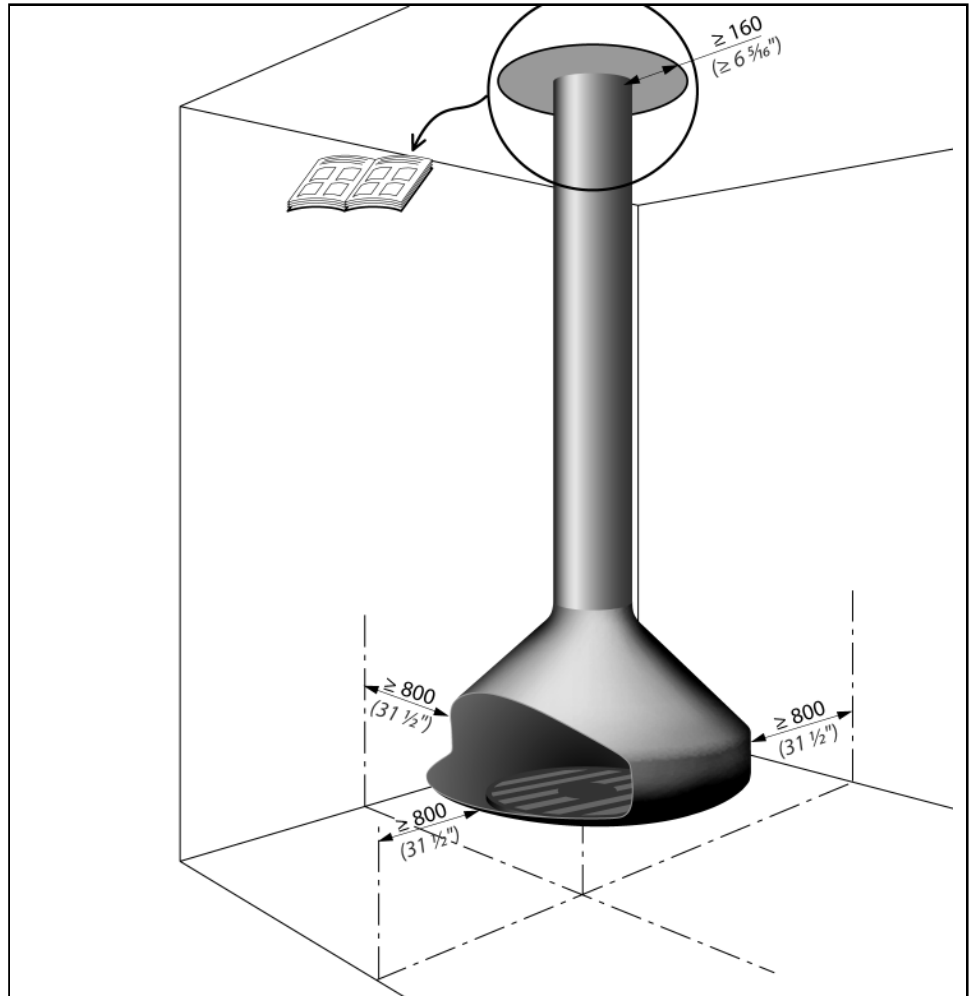

Bezpečnostná vzdialenosť od horľavých materiálov.

Varnostna razdalja glede na vnetljive materiale.

Säkerhetsavstånd från brännbart material.

Bezpečnostní vzdálenost od hořlavých materiálů.



 matériaux combustibles	 matériaux incombustibles et non dégradables sous l'effet de la chaleur
 combustible materials	 non combustible and heat resistant materials
 materiali combustibili	 materiali incombustibili o non degradabili sotto l'effeto del calore
 brennbares Material	 nicht brennbares und feuerbeständiges Material